

## Each role of seven wires

**Red**                      **Motor +**

**Black**                    **Motor -**

**Blue**                     **Brake -**

**Green**                    **enable/disable -**, which is signal from motor to control motor break or connect electrical circuit. Its function like a micro-switch to control motor, and it also can absorb some remain electrical-magnet. It integrate some synthetic features.

**Brown**                    **Limit signal**

**White**                    **Limit power 5V +**

**Yellow**                   **Ground**

## Use step below,

1. When standby, **red** and **black** connect 24V power, **green** suspending.
2. When entre into standby, **blue** connect yellow 2 seconds, the current of ground connection 300mA. Afterwards, keep 50% time connecting ground, the frequency 20k.
3. Before motor enter running, **green** connect ground 0.5 second in advance, the current of ground connection 60mA, **blue** suspending, **red** or **black** connecting ground.
4. **Brown** output a data package of limitation data each 20ms with password protection, Baud rate 9600. Decryption will be provided by us, when you require it during test.

To better understand, see following drawing, one of the typical use method,

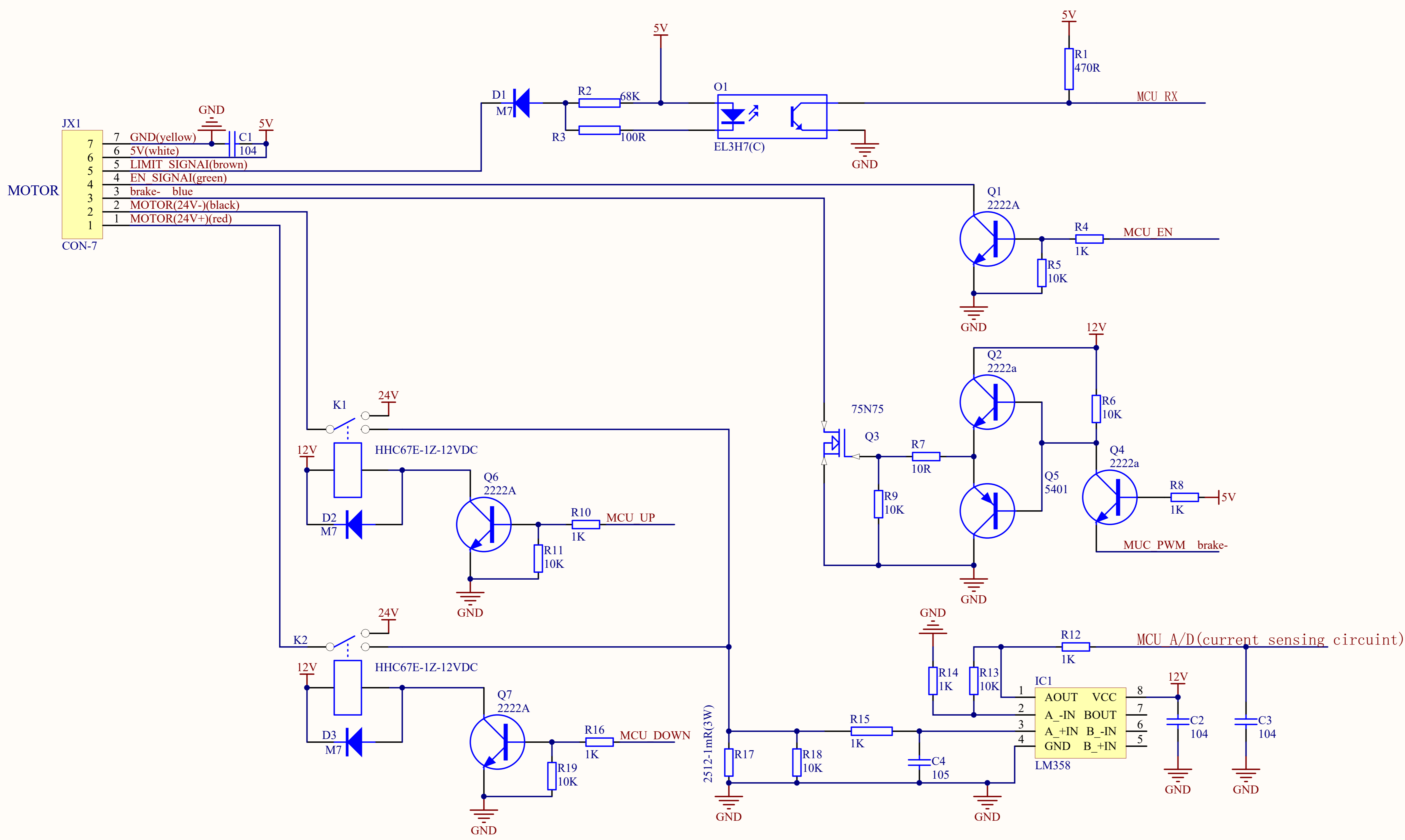

Title		
Size	Number	Revision
A4		
Date:	2021/11/24	Sheet of
File:	Drawn By:	



## ADVICE LETTER

We highly recommend customers use our motor with our own panel together, reason of perfect performance and quality warranty.

For few customers insist to apply our motor work with their own panel, we suggest following points,

1. Email this motor use manual, for customer learn more.

2. If customer have confidence to control motor with their own panel and would buy samples to try, we will provide samples and suggesting send it with our panel in case customer could be illuminated from it when they happen some problem.

3. If the motor finally work well with customer's panel, we will offer best service.

4-1. If the motor always can't work perfectly with customer own panel even though customer make modification, we are able to according customer's requirement to make panel if customer would let us cooperate and send us panel sample.

4-2. We promise make the same surface looks and inner structure as sample. We know it might not be allowed change anywhere if customer have got certification. For protect customer's designs and unique functions, we can sign law agreement of sole sales to guarantee sell this panel only to customer who let us made it. And could add your any new ideas and functions to it. Moreover, it should be cheaper than your present cost and also good quality.

Above just our preliminary opinion, final procedure depend on customers' requirements. Welcome any advice from you.

Kind regards